

HDT T-Cup Component Gear Sets

- **Precise Robotic Accuracy**
- **Large Center Through Hole**
- **Proven Reliability**



Sold & Serviced By:



Toll Free Phone (877) SERV098

Toll Free Fax (877) SERV099

www.electromate.com

sales@electromate.com

harmonic drive gearing
Precision Gearing & Motion Control

DIMENSIONS (mm)

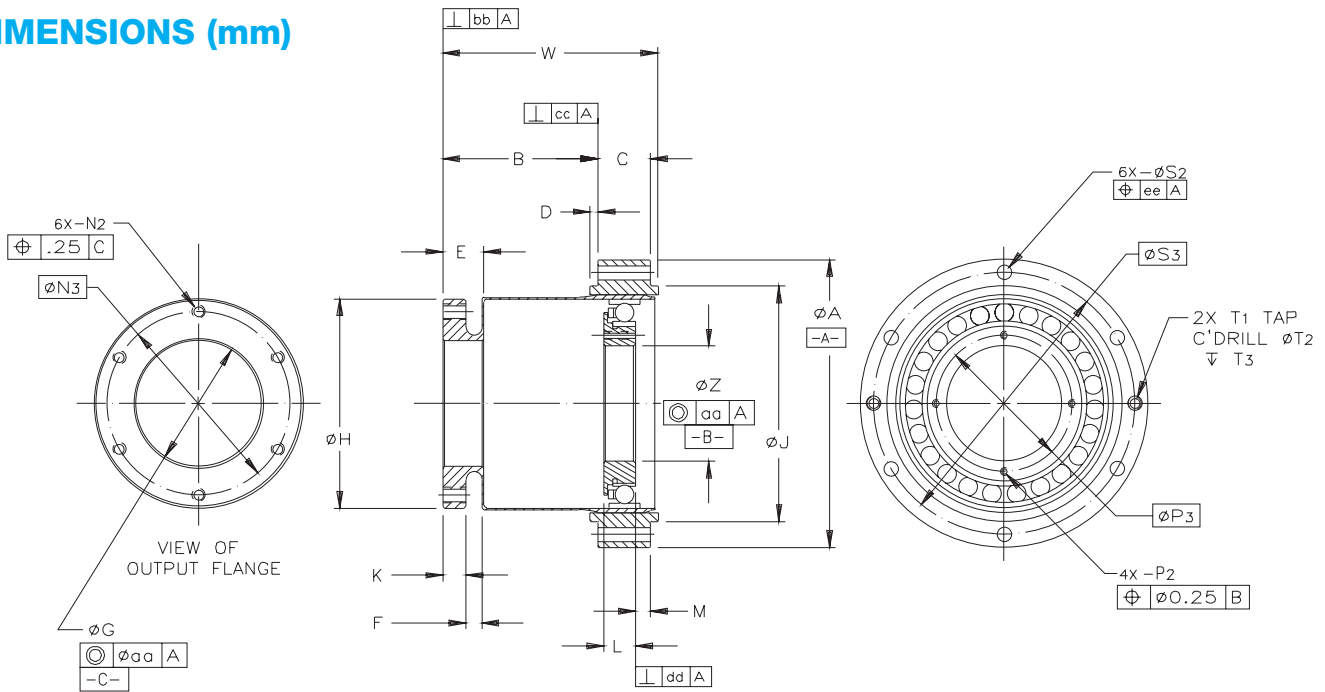

HDT	14	20	25	32	40	50
A	50 ⁺⁰ _{-0.016}	70 ⁺⁰ _{-0.019}	85 ⁺⁰ _{-0.022}	110 ⁺⁰ _{-0.022}	135 ⁺⁰ _{-0.025}	170 ⁺⁰ _{-0.025}
B	25.5±0.2	36.6±0.3	47.1±0.3	59.5±0.3	74.6±0.3	88.9±0.3
C	8	14	16	20	25	30
D	2	3	3	3	4	4
E	7	10.7	13.3	15.8	20.8	21.6
F	3.3	4.1	5.1	6.1	7.9	10.2
G	20 ^{+0.013} ₀	28 ^{+0.013} ₀	35 ^{+0.016} ₀	48 ^{+0.016} ₀	60 ^{+0.019} ₀	75 ^{+0.019} ₀
H	34	50	62	80	98	122
J	38 ⁺⁰ _{-0.016}	54 ⁺⁰ _{-0.019}	67 ⁺⁰ _{-0.019}	90 ⁺⁰ _{-0.022}	110 ⁺⁰ _{-0.022}	135 ⁺⁰ _{-0.025}
K	3.3	6.1	7.6	8.9	11.9	10.2
L	8.3	10.2	9.5	12.2	14.6	17.8
M	0.9	3	4.9	5.8	7.4	8.7
N2	M3	M4	M5	M6	M8	M10
N3	28	42	52	70	84	105
P2	M2.5	M3	M3	M3	M4	M4
P3	20	30	38	52	64	80
S2	3.5	3.5	4.5	5.5	6.6	9
S3	44	60	75	100	120	150
T1 (Jack Tap)	M3	M3	M4	M5	M6	M8
T2	3.5	3.5	4.5	5.5	6.6	9
T3	4	9.1	9.5	12	15.8	17
W	35.5	53.6	66.1	82.5	103.6	122.9
Z	14 ^{+0.011} ₀	22 ^{+0.013} ₀	30 ^{+0.013} ₀	44 ^{+0.016} ₀	54 ^{+0.019} ₀	70 ^{+0.019} ₀
aa	0.02	0.022	0.022	0.025	0.033	0.033
bb	0.028	0.028	0.036	0.044	0.05	0.06
cc	0.011	0.031	0.033	0.035	0.045	0.047
dd	0.02	0.025	0.036	0.036	0.048	0.048
ee	0.152	0.254	0.254	0.254	0.381	0.381

Sold & Serviced By:



Toll Free Phone (877) SERV098

Toll Free Fax (877) SERV099

www.electromate.com

sales@electromate.com

RATINGS TABLE

HDT Size	Standard Ratio*	RATED OUTPUT TORQUE						Maximum Repetitive Output Torque		Maximum Momentary Output Torque		Static Torque Limit		No-Load starting torque oz in. (Ncm)
		3500 RPM		1750 RPM		1000 RPM		lb in	Nm	lb in	Nm	lb in	Nm	
14	50	81	9.2	102	11.5	119	13.9	119	13.4	140	15.8	202	22.8	1.0 (0.7)
	72	81	9.2	102	11.5	119	13.9	119	13.4	200	22.6	202	22.8	
	80	81	9.2	102	11.5	123	13.9	140	15.8	200	22.6	238	26.9	
	100	81	9.2	102	11.5	123	13.9	180	20.3	200	22.6	306	34.6	
20	50	278	31.4	350	40.0	422	47.7	470	53	1120	127	1280	145	2.5 (1.8)
	60	281	31.8	355	40.1	428	48.4	470	53	1120	127	1280	145	
	80	281	31.8	355	40.1	428	48.4	470	53	1260	142	1240	140	
	100	297	33.6	375	42.4	452	51	690	78	1260	142	1620	183	
25	160	297	33.6	375	42.4	452	51	1120	127	1120	127	2480	280	
	50	476	54	600	68.0	723	82	830	94	1580	179	2570	290	5.0 (3.5)
	60	492	56	620	70.0	747	84	830	94	1580	179	2570	290	
	80	492	56	620	70.0	747	84	830	94	2050	232	2310	261	
100	492	56	620	70.0	747	84	1240	140	2050	232	3050	345		
32	160	492	56	620	70.0	747	84	1700	192	1900	215	4650	525	
	200	492	56	620	70.0	747	84	1580	178	1580	178	5320	601	
	50	952	108	1200	136	1446	164	1830	207	4000	452	4920	556	11.0 (7.8)
	60	989	111	1245	140	1500	169	1830	207	4000	452	4920	556	
80	989	111	1245	140	1500	169	1830	207	5000	565	4520	556		
100	989	111	1245	140	1500	169	2640	298	5000	565	5800	655		
40	160	989	111	1245	140	1500	169	4700	531	4700	531	9190	1038	
	200	989	111	1245	140	1500	169	4000	452	4000	452	10610	1199	
	50	1587	179	2000	226	2410	272	2760	312	6600	746	7330	828	20.0 (14.1)
	60	1646	186	2075	234	2500	282	2760	312	6600	746	7330	828	
80	1646	186	2075	234	2500	282	2760	312	9000	1017	6980	789		
100	2071	234	2610	295	3145	355	4070	460	9000	1017	9450	1068		
50	160	2071	234	2610	295	3145	355	7200	813	7200	813	14640	1654	
	200	2071	234	2610	295	3145	355	6600	746	6600	746	17010	1922	
	50	3016	341	3800	430	4579	577	5110	577	15500	1751	13910	1571	40.0 (28.3)
	60	3087	349	3890	440	4687	529	5110	577	15500	1751	13910	1571	
80	3087	349	3890	440	4687	529	5110	577	19000	2147	13060	1475		
100	3857	436	4860	549	5857	661	6500	734	19000	2147	16860	1904		
50	160	3857	436	4860	549	5857	661	13100	1480	17000	1921	26830	3031	
	200	3857	436	4860	549	5857	661	15500	1751	15500	1751	31190	3524	

* Unlisted ratios above 50:1 may be available. Consult our Engineering Department for availability

RATINGS AND OPERATING LIFE

The operating life expectancy of HDT Gear Sets is based on the rating of the ball bearings used for the input wave generator when run continuously at rated torque.

If gear sets are properly mounted and lubricated, gear tooth life will be well in excess of bearing life, provided maximum torque and speed limits are not exceeded. Flexspline life is infinite provided concentricity requirements are maintained. Ratings listed are for an L10 life of 3,000 hours. Median life, however, is 5 times this number.

Torque ratings for speeds other than those shown can be calculated by the following equations:

$$\text{Rating @ N RPM} = \frac{[1750]^{1/3}}{N} \times [\text{listed rating @ 1750 RPM}]$$

PREDICTED LIFE

$$L_{10} = \frac{(1750)}{N} [\text{listed rating @ 1750 RPM}]^3 \times 3000 \text{ hours}$$

Where T = mean torque and N = mean speed

MAXIMUM OUTPUT TORQUE

This is the maximum allowable torque that should be developed with dynamic torque at the input.

STATIC TORQUE LIMIT

This is the maximum allowable torque that should be applied to output when the input is locked. A typical example is the torque applied to the output during a work or machining operation when the Harmonic Drive is stationary.

MAXIMUM MOMENTARY OUTPUT TORQUE

Occasional momentary overload torques caused by collisions or emergency stops etc. should not exceed this value.

Sold & Serviced By:

ELECTROMATE

Toll Free Phone (877) SERV098

Toll Free Fax (877) SERV099

www.electromate.com
sales@electromate.com

FEATURES

- Zero backlash
- Precise positional accuracy
- Large center through hole
- High ratio
- High torque
- ± 5 arc second repeatability

APPLICATION EXAMPLE

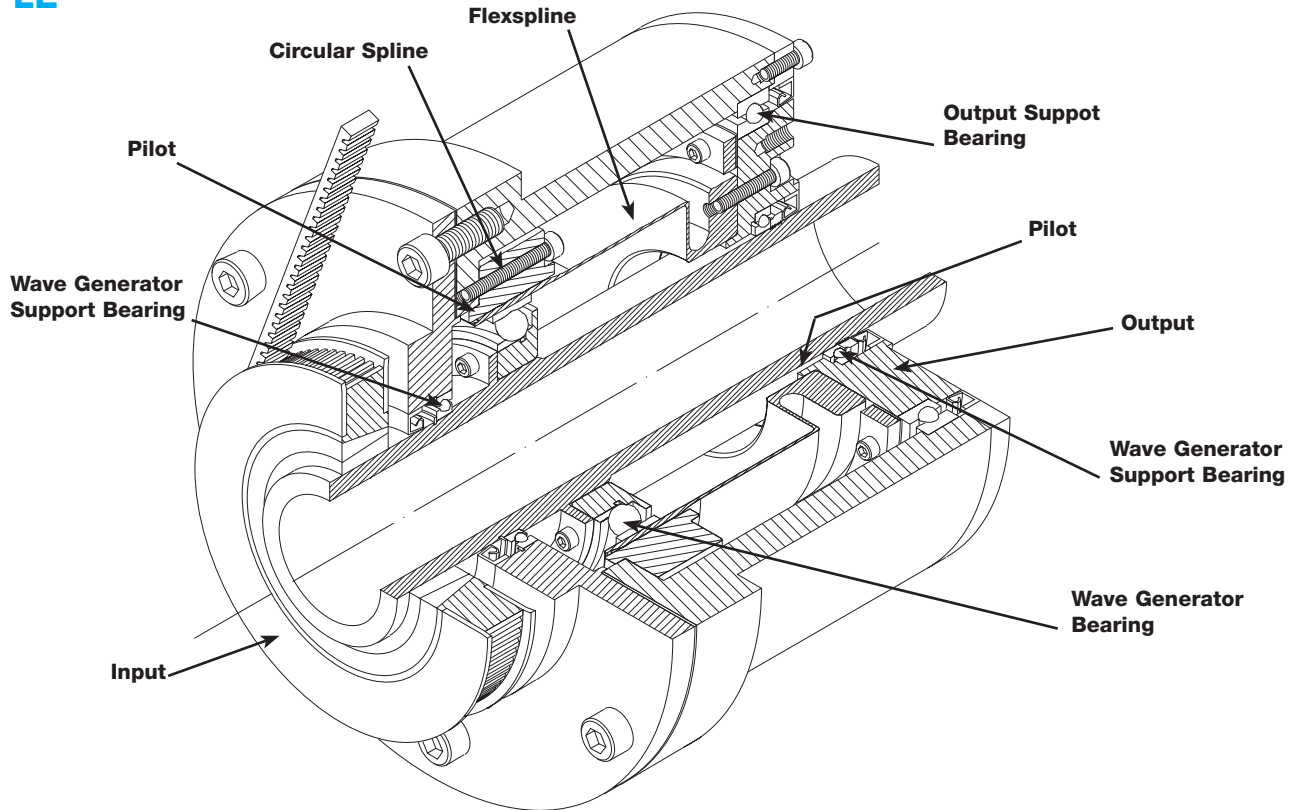

ASSEMBLY GUIDE LINES

To achieve proper performance from HDT gear sets, certain mounting and alignment requirements are necessary. Excessive deflection or improper alignment will affect the smoothness of motion and may cause premature failure.

CIRCULAR SPLINE

The circular spline must be located either on its outside diameter or on one of the two pilot diameters provided. Vibration can occur if the housing interface is allowed to distort the circular spline from roundness. Two jack screw holes are provided to facilitate removal.

FLEXSPLINE

Under all load conditions, the flexspline must be rigidly supported in a position concentric and perpendicular to the circular spline datums as shown on the installation drawing. Overhung loads from an external source require a suitable two bearing support or a single four point contact or cross roller bearing.

WAVE GENERATOR BEARING

The wave generator is not designed to support a shaft. Bearing support must be provided to maintain the require position relative to the circular spline datums. Axial restraint must be provided in both directions.

LUBRICATION

Sold & Serviced By:

Harmonic Drive gearing functions equally well in dry or with oil position provided it is adequately lubricated. Areas requiring lubrication are the circular spline and flexspline teeth, the wave generator bearing and the bore of the flexspline in the area of the wave generator contact.

Maximum input speed for each size is as follows:

HDT Size	MAX INPUT SPEED (rpm)	
	oil	grease
14	12000	6000
20	11000	5600
25	9000	4500
32	7000	3500
40	5600	2800
50	4500	2250

ELECTROMATE
 Toll Free Phone (877) SERV098
 Toll Free Fax (877) SERV099
www.electromate.com
sales@electromate.com

EFFICIENCY

The efficiency of HDT Gear Sets varies with speed, ratio, lubrication, and temperature. The following graphs show the approximate measured values of efficiency against percentage of rated torque. These values can be adjusted by a temperature factor; however, extremes of temperature or excessively low loading should be referred to our Engineering Department.

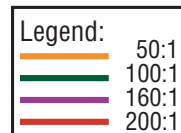
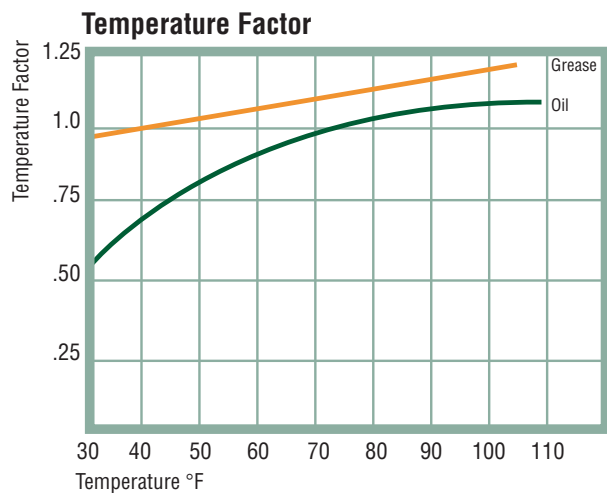
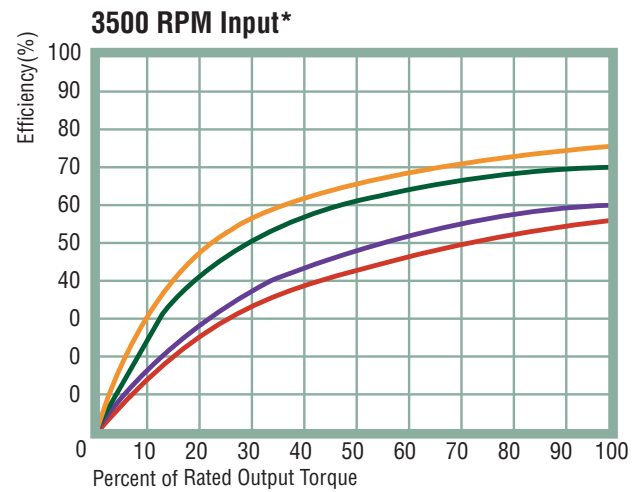
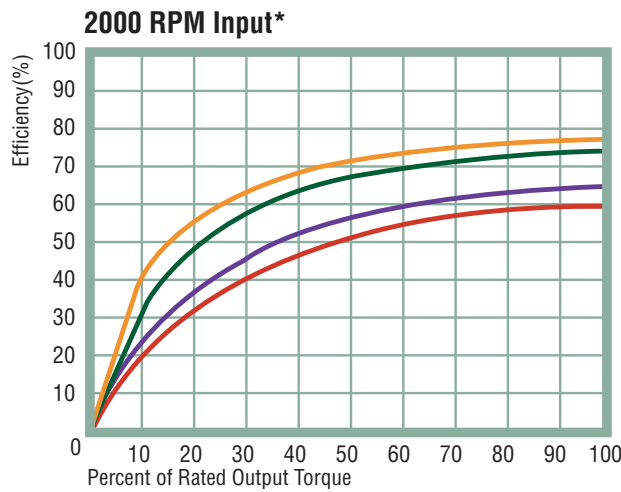
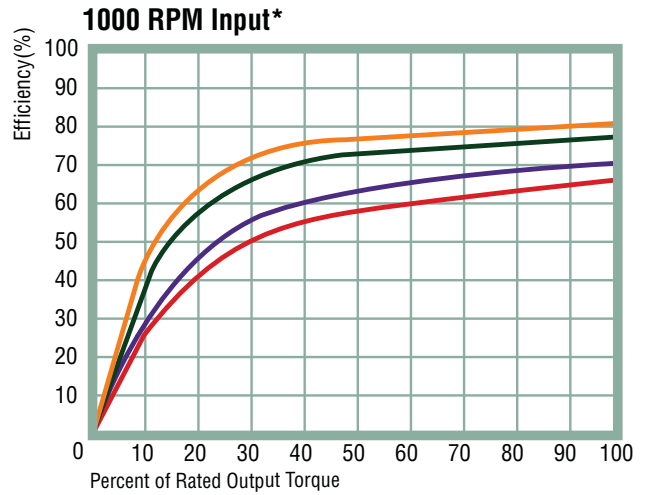
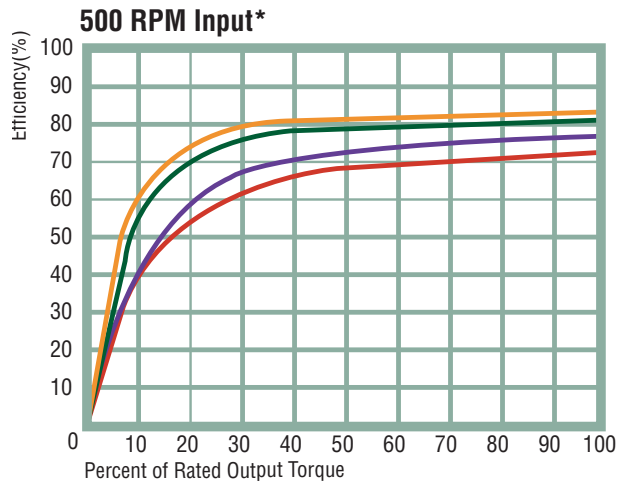

*ATF

Sold & Serviced By:

ELECTROMATE

Toll Free Phone (877) SERV098

Toll Free Fax (877) SERV099

www.electromate.com

sales@electromate.com

Sold & Serviced By:



Toll Free Phone (877) SERV098

Toll Free Fax (877) SERV099

www.electromate.com

sales@electromate.com